

Top mount (A) air- or (W) water-cooled icemaker

MCD400ABT – 115 V, 60 Hz, air-cooled

MCE400ABT – 230 V, 50 Hz, air-cooled

MCD400WBT – 115 V, 60 Hz, water-cooled

MCE400WBT – 230 V, 50 Hz, water-cooled



MCD400ABT icemaker shown on Follett 425-30 ice storage bin, sold separately

Compact, reliable icemaker for use with Follett ice storage bins. Stainless steel exterior with easily removable modern-style plastic facade. Both air- and water-cooled models use environmentally friendly R404A refrigerant. Production capacity up to 400 lbs (181 kg) of Chewblet ice in a 24-hour period.

High performance Maestro icemakers

- Stainless steel evaporator, auger and top bearing
- Oversized, heavy duty, tapered roller bearings ensure long, low-maintenance life
- Icemaker can be cleaned without contaminating ice
- Quiet production; no noisy harvest cycles

Lower utility bills

- Energy-efficient, no costly defrost cycles
- 25% less energy than comparable capacity cube machines
- 40% less water than comparable capacity cube machines

Easy installation

- Cord and hospital-grade plug provided (230 V models, cord only)

Space-saving design

- Compact design – only 18.875" wide x 20.75" deep x 17" high (479 mm x 591 mm x 432 mm)
- Perfect for use on Follett's 30" (762 mm) wide ice storage bin

Consumer-preferred Chewblet ice

- Preferred over cubes by more than 2:1
- More reliable dispensing than nugget or pellet ice
- Slow melting, maintains drink temperature and quality
- Drink performance comparable to cubes
- Higher displacement than cube ice
- Ice molds well for use in ice packs and food displays – 5/8" diameter x 1" (17 mm x 26 mm)

Accessories

- Water filter kit (item# 00130229)
- SafeCLEAN™ environmentally friendly icemaker cleaner (item# 00132001)
- Ice scoop (item# ABICESCOOP)
- San Jamar Saf-T-Ice® Guardian scoop system (item# 00146365)

JOB: _____

ITEM: _____

* Saf-T-Ice is a registered trademark of San Jamar, a division of the Coleman Group, Inc. in the United States.

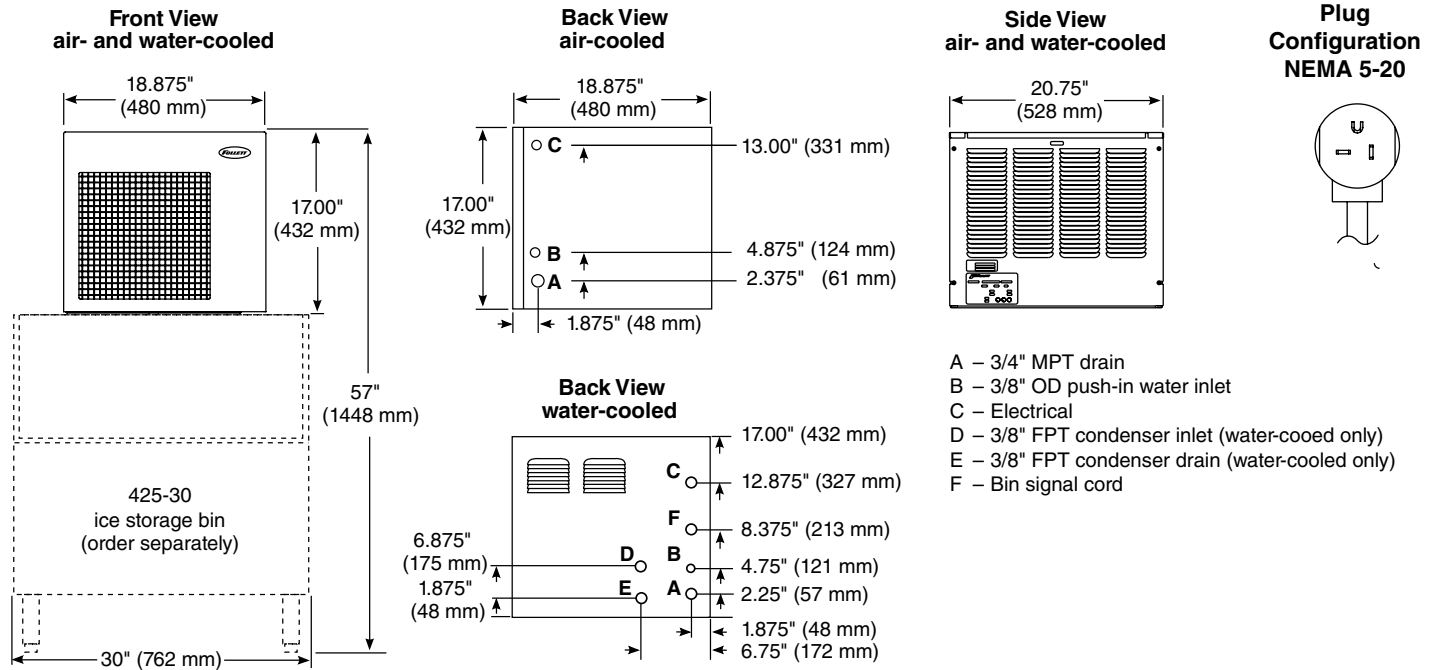

Required Clearances

6" (153 mm) between exhaust side of icemaker and any adjacent equipment.

Operating Limits

Ambient air temp. range – 50 F to 100 F (10 C to 38 C).
 Water temp. range – 45 F to 90 F (7 C to 32 C).
 Potable water pressure – 10 psi to 70 psi (69 kpa to 483 kpa).
 Condenser water pressure – 10 psi to 150 psi (69 kpa to 1035 kpa).

Standard electrical – MCD models, 115 V, 60 Hz, 1 phase, 11.0 amps, max. fuse 20 amps. Cord and plug provided with each icemaker, separate circuits required for each. If local code requires hard-wiring, separate disconnects also required.

Alternate electrical – MCE models, 230 V, 50 Hz, 1 phase, 6.5 amps, max. fuse 20 amps. Cord only. Ensure wiring is in accordance with all local codes.

Dimensions

Overall Dimensions		
Height	Depth	Width
17.0" (432 mm)	20.75" (528 mm)	18.875" (480 mm)

Approximate Shipping Weight 160 lbs (73 kg)

Specifications Icemaker to be Follett model number _____. Icemaker to be ____ air or ____ water-cooled, with stainless steel exterior panels and plastic front cover. Icemaker production to be approximately 400 lbs (181 kg) per day of Chewblet ice at air temp. of 70 F (21 C), water temp. of 50 F (10 C). Icemaker to use environmentally friendly R404A refrigerant and to be equipped with printed circuit board with diagnostics for simplified servicing. Icemaker to have stainless steel evaporator, auger and top bearings, heavy-duty tapered roller bearings, and low water safety circuit. Icemaker to be NSF, UL and cUL listed. 230 V models also CE compliant.

Maestro and SafeCLEAN are trademarks of Follett Corporation. Chewblet is a registered trademark of Follett Corporation, registered in the US. Follett reserves the right to change specifications at any time without obligation. Certifications may vary depending on country of origin.

Ice Production

Air-cooled icemaker capacity/24 hrs.

Inlet Water Temperature °F/C	Ambient Air Temperature F/C					
	F	60	70	80	90	100
	C	16	21	27	32	38
50	510	454	397	335	273	lbs.
10	232	206	180	152	124	kg.
60	482	435	389	329	270	lbs.
16	219	198	177	150	123	kg.
70	454	417	380	323	266	lbs.
21	206	190	173	147	121	kg.
80	424	385	347	297	247	lbs.
27	193	175	158	135	112	kg.
90	394	354	313	270	227	lbs.
32	179	161	142	123	103	kg.

Water-cooled icemaker capacity/24 hrs.

Inlet Water Temperature °F/C	Ambient Air Temperature F/C					
	F	60	70	80	90	100
	C	16	21	27	32	38
50	451	447	442	437	428	lbs.
10	204	202	200	199	194	kg.
60	423	413	409	399	394	lbs.
16	192	187	185	181	179	kg.
70	394	390	380	371	361	lbs.
21	179	177	172	168	163	kg.
80	371	361	352	342	333	lbs.
27	168	163	160	155	151	kg.
90	352	342	333	323	309	lbs.
32	160	155	151	146	140	kg.

Water Flow Requirements for Water-Cooled Condensers

Water Temp. °F/°C	70/21
Water Flow:	
Gallons/100 lbs of ice	73
Liters/46 kg of ice	276

Energy Consumption

KWH per 100 lbs (46 kg) ice†	
Air-cooled	5.7
Water-cooled	5.5

† Air temp. 90 F (32 C); water temp. 70 F (21 C)

Heat Rejection Data

Model	Heat rejected in BTU/hr	
	to air	to water
Air-cooled	5000	n/a
Water-cooled	1400	3600

Water consumption

12.6 gal (48 L) of potable water usage per 100 lbs (46 kg) of ice.